

KOMATSU®

GD555-5

GD
555

HORSEPOWER

Gross: 146 kW 196 HP / 2000 min⁻¹

Net: 144 kW 193 HP / 2000 min⁻¹

OPERATING WEIGHT

15135 kg (with ripper 17065 kg)

BLADE LENGTH

3.71 m



Photos may include optional equipment.

WALK-AROUND





PRODUCTIVITY

- ▮ Long Wheelbase & Short Turning Radius
- ▮ Optimized Hydraulic & Cooling System

CONTROL

- ▮ Outstanding Power Transmitting System

COMFORT

- ▮ Excellent visibility
- ▮ Spacious Interior

SERVICEABILITY

- ▮ Machine Monitoring System
- ▮ Easy Maintenance Design

KOMTRAX

- ▮ Energy Saving Operation Report
- ▮ Equipment Management Support
- ▮ Optimal Strategy for Efficient Work

ECOLOGY & ECONOMY

- ▮ Engine power mode selection system
- ▮ Circumference dynamic noise

GD555-5

HORSEPOWER	Gross:	146 kW 196 HP/2000min ⁻¹
	Net:	144 kW 193 HP/2000min ⁻¹
OPERATING WEIGHT	15135 kg (with ripper 17065 kg)	
BLADE LENGTH	3.71 m	

DASH 5 SERIES MOTOR GRADERS



The Perfect Fit for the Jobsite

Most of motor grader applications requires accuracy and versatility. For that, motor graders should be easy to operate in any situations of work.

To realize this ease of operation, Komatsu Dash 5 Series Motor Graders are totally improved from overview design down to each element.

Our design philosophy contributes to our motor graders fitting in every jobsites from road construction to snow removal, and brings more productivity to every operators from beginner to expert.

Get More Versatility

The GD555-5 attempts to get more versatility in the middle class graders which are used in various jobsites. With variety of work equipments and stretched wheelbase that is easier to accommodate longer blade, all elements are enhance job efficiency.

Moreover, the torque converter transmission provides easy control, resulting in more precise operation in any application.



PRODUCTIVITY**Long Wheelbase & Short Turning Radius**

The long wheelbase enables high leveling performance with a long blade and easier to set the blade position. Long wheelbase also contributes to expanding blade reach in combination with large articulation angle. Additionally the minimum turning radius still short with wide steering angle, serves high maneuverability.

Optimized Hydraulic & Cooling System**Control valve**

Komatsu Multifunctional Control Valve with Closed Load Sensing System (CLSS) Hydraulic System enable the constant cylinder speed, excellent multifunctional operation ability and fine control.

1) Low operating effort

Implement controls are designed to reduce operator fatigue. They feature short lever throws and effort in both directions. Properly spaced control levers and short lever throws allow the operator to use multiple controls with one hand.

2) Balanced flow

When the operator uses several controls at the same time, flow is proportional to ensure several implements can operate simultaneously.

3) Constant implement speed

Implement speed is constant regardless of engine speed because of the large pump output and proportional flow control function.

Power on demand

Normally, the variable displacement pump idles at low output. When it senses a load requirement, the pump supplies quick flow and pressure to match the demand.

The result is less hydraulic system heat, quick response and lower fuel consumption.

Hydraulic cooling fan

The newly designed cooling fan eliminates excessive cooling capacity by controlling air flow rate according to work load.



Outstanding Power Transmitting System

The GD555-5 features Lock-up Torque Converter Transmission for pursuing ease of operation.

This unique system provides both efficiency of direct drive and controllability of Torque Converter drive.

With this outstanding power transmitting system, the GD555-5 delivers advanced productivity in any applications from fine grading to heavy grading.

Torque Converter Features

High controllability

- Eliminates engine stalling and inching pedal operation
- Smooth starting, good controllability in fine grading
- Easy travelling, automatic gear shifting
- Reduce excessive tire slipping

Torque multiplication

- Multiply over twice torque, provides much torque in heavy grading, ditching and ripping
- Stable engine speed, reduce shift changing during road maintenance and snow removal

Lock-up function

- Prevents loss of efficiency



Transmission Mode Selection

There is two transmission mode to enhance productivity. With the push of a button, transmission mode is selected to fit in working condition and preference of operators.

Auto mode

Drive with Torque Converter in all shift position. This mode maximizes Torque Converter benefits. Lock-up will works in F5-F8 and R3-R4 position. Shifting F8 position serves automatic shifting through F4-F8 in responsible to machine speed.

Manual mode

Works like a same way as conventional power shift, by engaging lock up clutch with all gears. This mode maximizes efficiency of direct shifting. In reverse travelling, works same way as Auto mode, serves less shift lever operation frequency.

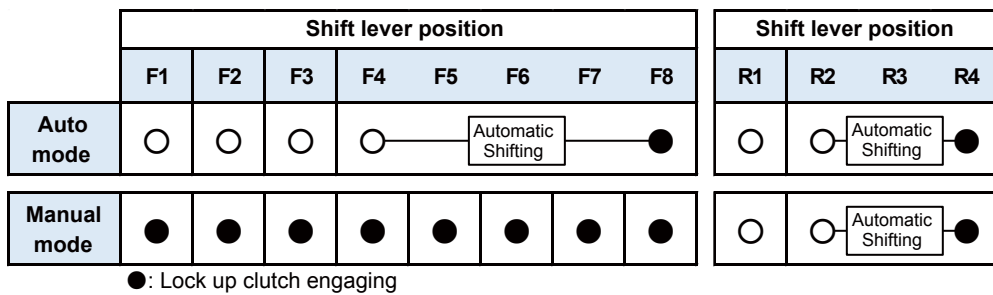

Anti Stall

Prevents engine stalling while Lock up by automatically disengaging the lock up clutch and shifting to torque converter state. Torque converter provides much torque to continue to work as it is, never needs to restart the engine and shift the gear.

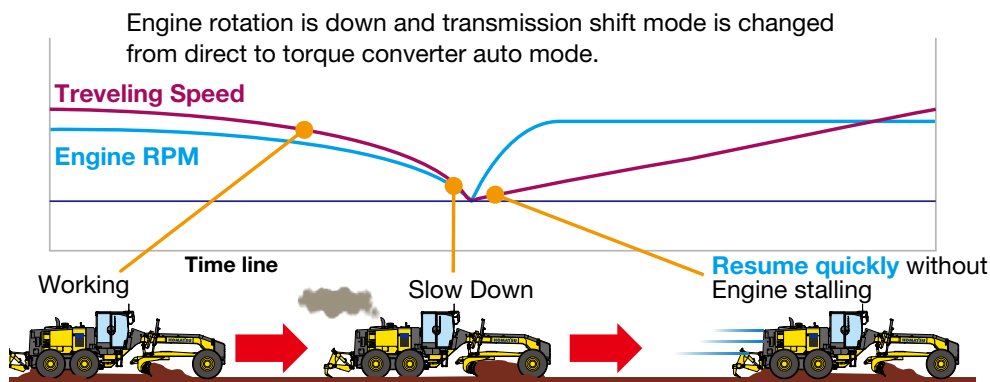

Creep Mode

Torque converter transmission introduces Creep Mode which provides constant low speed without acceleration and brake control. Optimized machine speed and great stability of torque converter boosts up precise control during fine grading.

Power Train Protection

Electronic Over-Speed Protection Prevents downshifting until reducing the travel speed to the safe range of shift changing. FR Inhibitor restricts excessive shuttle shifting at high traveling speed.

Reduce Shift Shock for Driving Comfort

Torque Converter allows to absorb torque fluctuation of the engine. Even in shifting the gear during Lock up, torque converter temporarily absorb shift shock and contributes high driving comfort.

COMFORT



Excellent Visibility

Excellent visibility by hexangular cab with front Y shape pillar and rear layout side pillar boost operator's confidence and productivity in all grader applications. Well-positioned blade linkage provides an unobstructed view of the moldboard and front tires. The tapered engine hood provides good visibility to the rear of the machine, especially the rear ripper.

ROPS Cab



Low profile cab is designed to ensure ROPS/FOPS (ISO 3471/ISO 3449) certification.



Rear (ripper) view from the cab

Spacious Interior

Low noise

New hydraulically driven fan and redesigned layout of the cooling system achieve a low noise level.

Operator's ear dynamic noise level (ISO6396) 74 dB (A)

Suspension seat

The suspension, fabric covered seat which is adjustable to the operator's weight is provided as standard.

The suspension seat dampens vibrations transmitted from the machine and reduces operator fatigue.

The seat features fold-up armrests and a retractable seat belt.



Air conditioner

Well-positioned air conditioning vents keep the operator comfortable through a wide range of outside conditions.



Electric throttle control

The RPM mode select switch allows the operator to perfectly match the working condition by selecting between three modes: Auto, Off and Manual. The engine speed set by throttle switch is temporarily cancelled when operating the brake/acceleration pedal at Auto mode.



Storage space

The cab includes built-in storage space for personal items such as a lunch box, coffee cup, and a coat hook.



Adopted DC 12 V electrical outlet (Optional)

12 V DC outlets is included in the operator's cab.

Adjustable control console

The control console is adjustable backward and forward to facilitate entry and exit from the cab. The steering wheel also tilts to the operators preference.

Machine Monitoring System

The machine monitor displays various machine information and allows for various settings of the machine. Displays maintenance information, operation records, etc. By using the switch panel, you can display various user menus on the Liquid Crystal Display (LCD) unit screen and perform the settings of the machine.

Clear character display

During normal operation, the service meter/odometer is displayed in this area. If an abnormality or machine overload occurs, or if machine maintenance and inspection are required, action codes appear on the display to allow the operator to take appropriate action.



- ① Gear position
- ② Speed meter
- ③ ECO indicator
- ④ Power mode indicator
- ⑤ Character display
 - Service meter
 - Odometer
 - Maintenance information
 - Error code
 - Fuel consumption information

Easy Maintenance Design

Accessibility to service areas

- Easy and more safety refueling from the ground
- Large hinged service door serves wide inspection area
- Service meter is integrated with the machine monitor
- Distinguishable fuse panel in the cab
- Tandem oil check points is easy to access
- Spin-on filters for quick replacing
- Oil drains located near ground



Ground refueling

Power train components

With a modular design, you can remove the engine, transmission or final drives independently for quick service.

Disconnect switch

For inspection and maintenance, the batteries can be disconnected with this switch when repairing the machine or checking batteries.



Tool box

KOMTRAX

The Komatsu remote monitoring and management technology provides insightful data about your equipment and fleet in user-friendly format.

Energy Saving Operation Report

KOMTRAX delivers the energy-saving operation report based on the operating information such as fuel consumption, load summary and idling time, which helps you efficiently run a business.

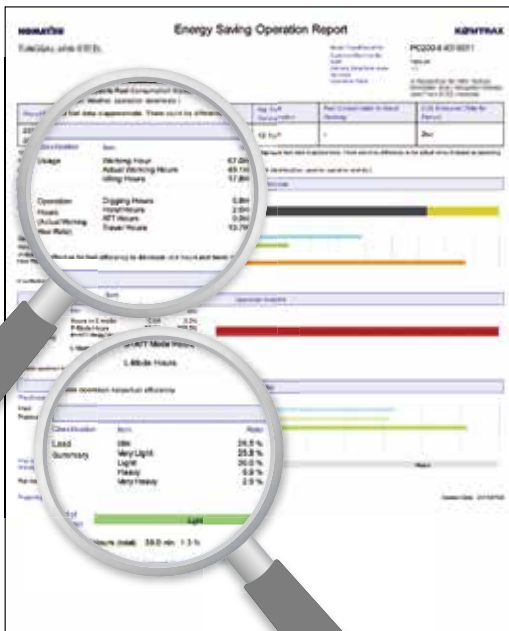

This report image is an example of hydraulic excavator

Equipment Management Support

Through the web application, a variety of search parameters are available to quickly find information about specific machines based on key factors. Moreover, KOMTRAX finds out machines with problems from your fleet and shows you through an optimal interface.

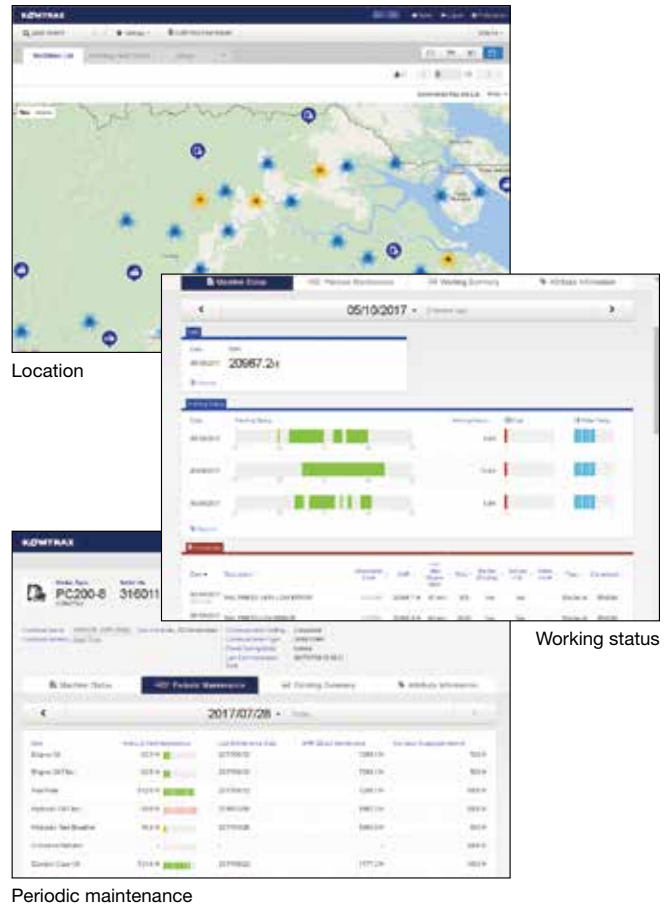

The report contents and data depend on the machine model.

Optimal Strategy for Efficient Work

The detailed information that KOMTRAX puts at your fingertips helps you manage your fleet conveniently on the web anytime, anywhere. It gives you the power to make better daily and long-term strategic decisions.



ECOLOGY & ECONOMY



Komatsu technology



Komatsu uniquely develops all major components including total control system, like engines, electronics, and hydraulic components.

With this “Komatsu technology” and continuous customer feedback, Komatsu has been achieving great advancements of technology.

This resulted in new generation of high performance and environmentally friendly products.

High performance engine

Powerful turbocharged and air-to-air aftercooled Komatsu SAA6D107E-1 engine provides 144 kW 193 HP. This engine realizes high power with low fuel consumption by Common Rail Injection system (CRI), and thus it delivers higher work speeds with high horsepower. In addition, high torque at low speed, impressive acceleration, and low fuel consumption ensure maximum productivity.

This engine is U.S. EPA Tier 3 and EU Stage 3A emissions certified.

Engine power mode selection system

The system allows selection of the appropriate mode between two modes E or P mode according to each working condition. The mode is easily selected with a switch in the operator's cab.

• P mode

Greater productivity can be attained by taking full advantage of high output power. It is appropriate for job sites where the motor grader meets high resistance.

• E mode

This mode is selected for maximum economy and lighter work applications. This feature provides the appropriate power and better fuel consumption.



unit: kW(HP)

	P mode		E mode	
	AUTO	MANU.	AUTO	MANU.
F1	118 (158)	118 (158)	104 (140)	104 (140)
F2				
F3	131 (176)	131 (176)	118 (158)	118 (158)
F4				
F5				
F6				
F7	114 (193)	114 (193)	131 (176)	131 (176)
F8				
R1	118 (158)	118 (158)	104 (140)	104 (140)
R2				
R3	131 (176)	131 (176)	118 (158)	118 (158)
R4				

Circumference dynamic noise

The dynamic circumference noise is lowered by various kind of countermeasures like the hydraulic driven cooling fan ,the variable displacement pump and etc.

Circumference dynamic noise level (ISO6395) 111.4 dB (A)



Hydraulic driven cooling fan

Double seal cylinder (Blade side shift cylinder)

A double-seal design is used for the blade side shift cylinder, which is installed near the ground, and thus susceptible to damage by dirt.

Environmentally friendly by preventing oil leakage from the cylinder.

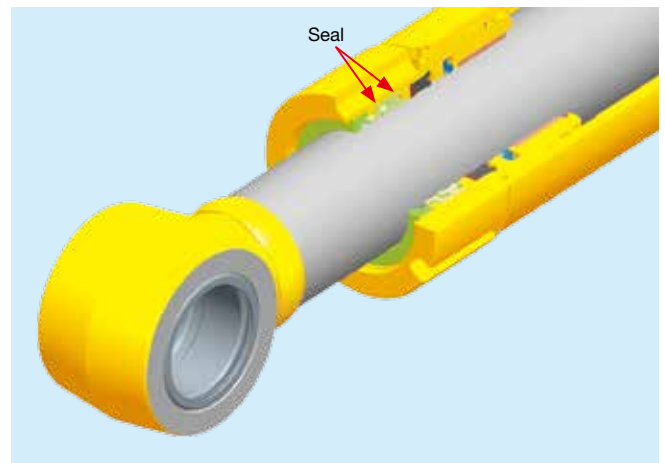

WORK EQUIPMENTS



Komatsu Genuine Work Equipment

Moldboard options

Available both 3.7 m (12 ft) and 4.3 m (14 ft) moldboards. Optional thicker blades are also available for heavy duty application.

Front blade

The front blade is a front mounted equipment used for spreading materials such as gravel piles or blading at the front of the machine where is difficult to access with the moldboard.

Ripper and scarifier

Digs up hard material cannot be removed by the moldboard. The scarifier can accommodate up to 11 teeth, the ripper also accommodate up to 5 shanks and 9 scarifier teeth.



KOMATSU TOTAL SUPPORT**Komatsu Total Support**

To keep your machine available and minimize operation cost when you need it, Komatsu Distributor is ready to provide variety of support before and after procuring the machine.

Fleet recommendation

Komatsu Distributor can study the customer's job site and provide the most optimum fleet recommendation with detailed information to meet all of your application needs when you are considering to buy new machines or replace the existing ones from Komatsu.

**Product support**

Komatsu Distributor gives the proactive support and secures the quality of the machinery that will be delivered.

Parts availability

Komatsu Distributor is available for emergency inquiry by the customers for genuine, quality guaranteed Komatsu parts.

Technical support

Komatsu product support service (Technical support) are designed to help customer. Komatsu Distributor offers a variety of effective services how much Komatsu is dedicated to the maintenance and support of Komatsu machine.

- Preventive Maintenance (PM) clinic
- Oil & Wear analysis program

Repair & maintenance service

Komatsu Distributor offers quality repair and maintenance service to the customer, utilizing and promoting Komatsu developed programs.

Komatsu Reman (Remanufactured) components

Komatsu Reman products are the result of the implementation of the Komatsu global policy which establishes and agrees to reduce the owning, operating and total Life Cycle Costs (LCC) to Komatsu's customer through high quality, prompt delivery and competitively priced in own remanufactured products (QDC).



SPECIFICATIONS



ENGINE

Model KOMATSU SAA6D107E-1
 Type Water-cooled, 4-cycle, direct injection
 Aspiration Turbocharged and air to air aftercooled
 Number of cylinders 6
 Bore 107 mm
 Stroke 124 mm
 Piston displacement 6.69 L
 Gross horsepower (Manual mode)
 P-mode
 Gear 1-3 120 kW 161 HP/2000 min⁻¹
 Gear 4-6 134 kW 179 HP/2000 min⁻¹
 Gear 7-8 146 kW 196 HP/2000 min⁻¹
 E-mode
 Gear 1-3 107 kW 143 HP/2000 min⁻¹
 Gear 4-6 120 kW 161 HP/2000 min⁻¹
 Gear 7-8 134 kW 179 HP/2000 min⁻¹
 Net flywheel horsepower* (Manual mode)
 P-mode
 Gear 1-3 118 kW 158 HP/2000 min⁻¹
 Gear 4-6 131 kW 176 HP/2000 min⁻¹
 Gear 7-8 144 kW 193 HP/2000 min⁻¹
 E-mode
 Gear 1-3 104 kW 140 HP/2000 min⁻¹
 Gear 4-6 118 kW 158 HP/2000 min⁻¹
 Gear 7-8 131 kW 176 HP/2000 min⁻¹
 Maximum torque 880 Nm 89.8 kgfm/1450 min⁻¹
 Torque rise 29 %
 Fan speed Max. 1500 min⁻¹
 Air cleaner 2-stage, dry-type
 Electrical 24 V with 60 A alternator
 Battery 2, low maintenance plus, 12 V, 1146 cca

* : Net horsepower output for standard (SAE J1349) including air cleaner, alternator (Not charging), water pump, lubricating oil, fuel pump, muffler and fan running at minimum speed.

EPA Tier 3 and EU Stage 3A emissions certified.



TRANSMISSION AND TORQUE CONVERTER

Full power shift transmission with integral free wheeling stator torque converter and lock-up.

Speeds (at rated engine speed)

Gear	Forward	Reverse
1st	3.4 km/h	4.5 km/h
2nd	5.0 km/h	9.2 km/h
3rd	7.0 km/h	20.3 km/h
4th	10.2 km/h	40.3 km/h
5th	15.4 km/h	—
6th	22.3 km/h	—
7th	30.6 km/h	—
8th	44.3 km/h	—



TANDEM DRIVE

Oscillating welded box section 520 mm x 202 mm
 Side wall thickness: Inner 22 mm
 Outer 19 mm
 Wheel axle spacing 1525 mm
 Tandem oscillation 11° forward, 13° reverse



FRONT AXLE

Type Solid bar construction welded steel sections
 Ground clearance at pivot 620 mm
 Wheel lean angle, right or left 16°
 Oscillation, total 32°



REAR AXLE

Alloy steel, heat treated, full floating axle with lock/unlock differential.



STEERING

Hydraulic power steering providing stopped engine steering meeting ISO 5010.
 Minimum turning radius 7.3 m
 Maximum steering range, right or left 49°
 Articulation 25°



BRAKES

Service brake Foot operated, sealed oil disc brakes, hydraulically actuated on four tandem wheels, 13691 cm² total braking surface.
 Parking brake Manually actuated, spring applied, hydraulically released caliper.



FRAME

Front Frame Structure
 Height 300 mm
 Width 300 mm
 Side 12 mm
 Upper, Lower 25 mm



DRAWBAR

A-shaped, u-section press formed and welded construction for maximum strength with a replaceable drawbar ball.
 Drawbar frame 210 mm x 25 mm



CIRCLE

Single piece rolled ring forging. Four circle support shoes with replaceable wear surface. Circle teeth hardened on front 180° of circle.
 Diameter (outside) 1530 mm
 Circle reversing control hydraulic rotation 360°



MOLDBOARD

Hydraulic power shift fabricated from high carbon steel. Includes replaceable metal wear inserts, cutting edge and end bits. Cutting edge and end bits are hardened.

Dimensions 3710 mm x 645 mm x 19 mm
 Arc radius 329 mm
 Cutting edge 152 mm x 16 mm
 Blade pull

Base GVW 8795 kgf
 With scarifier GVW 8860 kgf
 With ripper GVW 9675 kgf

Blade down pressure

Base GVW 6675 kgf
 With scarifier GVW 7585 kgf
 With ripper GVW 8010 kgf



BLADE RANGE

Circle center shift:

Right 590 mm
 Left 550 mm

Moldboard side shift:

Right 820 mm
 Left 820 mm

Maximum shoulder reach outside rear tires (frame straight)

Right 2000 mm
 Left 1960 mm

Maximum lift above ground 505 mm
 Maximum cutting depth 815 mm
 Maximum blade angle, right or left 90°
 Blade tip angle 40° forward, 5° backward



HYDRAULICS

Load-sensing closed center hydraulics with variable displacement piston pump. Short stroke/low effort direct acting control valves with preselected maximum flow setting to each function. Double acting anti-drift check valves on blade lift, tip, circle shift, articulation, and leaning wheels.

Output (at engine rated rpm) 200 L/min
 Standby pressure 3.4 MPa 35 kgf/cm²
 Maximum system pressure 20.6 MPa 250 kgf/cm²



INSTRUMENT

Electric monitoring system with diagnostics:

Gauges:

Standard articulation, engine coolant temperature, fuel level, speed meter, T/M shift indicator, engine tachometer torque converter oil temperature

Warning lights/Indicator:

Standard battery charge, brake oil pressure, inching temperature, directional indicator, engine oil pressure, hydraulic oil temperature, heater signal, lift arm lock, parking brake, differential lock, torque converter oil temperature, eco, P mode, rpm set, high beam, working lights

Optional blade accumulator



CAPACITIES (REFILLING)

Fuel tank 416 L
 Cooling system 24.9 L
 Crank case 23.1 L
 Transmission 45 L
 Final drive 17 L
 Tandem housing (each) 57 L
 Hydraulic system 69 L
 Circle reverse housing 7 L



OPERATING WEIGHT (APPROXIMATE)

Includes lubricants, coolant, full fuel tank

Total 15135 kg
 On rear wheels 10995 kg
 On front wheels 4140 kg

With front mounted scarifier:

Total 15780 kg
 On rear wheels 11075 kg
 On front wheels 4705 kg

With rear mounted ripper and front push plate:

Total 17065 kg
 On rear wheels 12095 kg
 On front wheels 4970 kg



SCARIFIER (OPTIONAL)

Middle, V-type

Working width 1430 mm
 Scarifying depth, maximum 205 mm
 Scarifier shank holders 11
 Scarifier shank holders spacing 138 mm

Rear

Working width 2186 mm
 Scarifying depth, maximum 165 mm
 Scarifier shank holders 9
 Scarifier shank holders spacing 267 mm



RIPPER (OPTIONAL)

Ripping depth, maximum 425 mm
 Ripper shank holders 5
 Ripper shank holder spacing 534 mm
 Penetration force 8380 kgf
 Pry out force 13335 kgf
 Machine length increase, beam raised 765 mm



DIMENSIONS

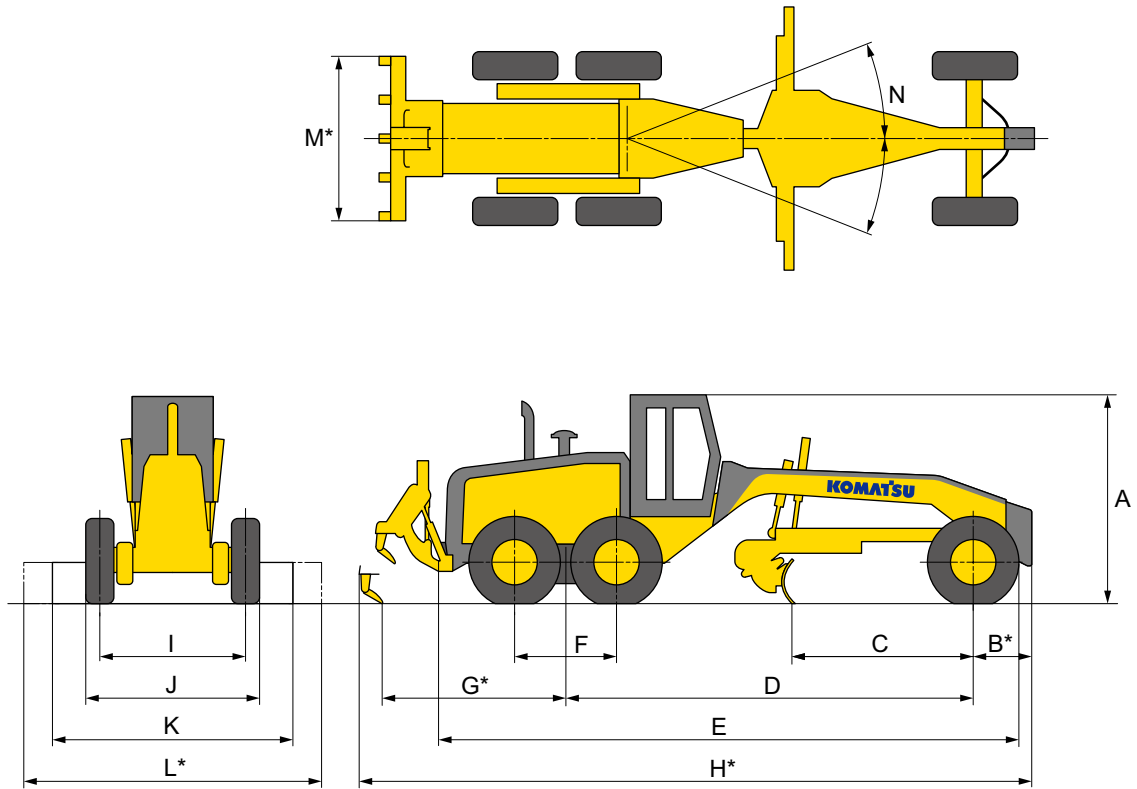

A	Height: Low profile cab	3200 mm
B*	Center of front axle to counterweight (Pusher)	927 mm
C	Cutting edge to center of front axle	2380 mm
D	Wheel base to center of tandem	6270 mm
E	Front tire to rear bumper	8995 mm
F	Tandem wheelbase	1525 mm
G*	Center of tandem to back of ripper	2780 mm
H*	Overall length	10365 mm
I	Track of gauge	2060 mm
J	Width of tires	2485 mm
K	Width of standard moldboard	3710 mm
L*	Width of optional moldboard	4320 mm
M*	Ripper beam width	2305 mm
N	Articulation, left or right	25°

*optional



WHEELS, FRONT AND REAR

Tire	Rim size	Rim structure
14.00-24	8"	Multi-piece
14.00-24	9"	Single-piece
14.00-24	10"	Multi-piece
14.00R24	9"	Single-piece
14.00R24	10"	Multi-piece
17.5R25	13"	Single-piece



STANDARD EQUIPMENT

Engine and Related Items

- Double element air cleaner and dust indicator.
- Engine: Komatsu SAA6D107E-1 turbocharged and air-to-air aftercooled, standard VHPC, 140-193 net horsepower
- Fuel line pre-filter
- Hood-sides for engine compartment
- Air intake extension

Electrical Systems

- Alarm, back-up
- Alternator, 60 A/24 V
- Battery, extreme duty, 1146 cca each
- Dome light, cab
- Horn, electric
- Lights: back-up, stop, tail, directional, headlights (2 halogen type, front bar mounted)
- Work lamps: front (4), rear (2)
- Speedometer
- Indicators: parking brake, differential lock, blade float, lift arm lock, high beam, eco, engine P mode, cooling fan reverse, rpm set, engine oil pressure, battery charge, brake oil pressure, differential oil temperature

Operator Environment

- Cab: low profile enclosed ROPS/FOPS (ISO 3471/ISO 3449) with safety tinted glass windows with wiper and washer
- Air conditioner (R134a)
- Console, adjustable with instrument panel monitoring system
- Mirrors: interior cab, right and left exterior mirrors
- Seat, deluxe adjustable cloth with retractable seat belt
- Sound suppression, cab and floor mat
- Wipers, front, doors, and rear
- 12 V (10 A) power port

Power Train

- Dual mode transmission (8F-4R) power shift, direct drive and torque converter with auto shift
- Axle, rear full floating, planetary type
- Service brakes, fully hydraulic wet disc
- Brake, parking, spring applied, hydraulic release, disc type
- Differential, lock/unlock

Work Equipment and Hydraulics

- Circle, drawbar mounted, 360° rotation hydraulic blade lift and circle side shift
- Circle slip clutch
- Hydraulic system, closed center, load sensing
- Moldboard: 3710 mm x 645 mm x 19 mm with replaceable end bits, through hardened cutting edges
- 152 mm x 16 mm, hydraulic blade side shift and hydraulic tilt with anti-drift check valves. Maximum moldboard angle position 90° right & left
- Steering, full hydraulic with tilt steering wheel plus leaning front wheels and frame articulation w/anti-drift check valves
- 9 section hydraulic control valve
- Blade lift float detent style, LH and RH

Other Standard Equipment

- Painting, Komatsu standard color scheme
- Steps and handrails, rear, right, and left side
- Vandalism protection includes lockable access to fuel tank, battery cover, and engine side covers
- Tool box with lock
- Fuel tank, ground level access
- Battery disconnect switch



OPTIONAL EQUIPMENT

- Accumulators, anti-shock for blade lift
- 10 section hydraulic control valve
- Cab mount work lamps (4)
- General toolkit
- Pre-cleaner, Turbo II
- Pusher plate, additional
- Additional heater
- AM/FM radio
- Moldboard, 3710 mm x 645 mm x 25 mm
- 4320 mm x 645 mm x 19 mm
- 4320 mm x 645 mm x 25 mm with replaceable end bits, through-hardened cutting edges 152 mm x 16 mm
- Front blade
- Ripper, assembly, rear mounted
- Ripper shanks and points, 2 additional
- Scarifier, assembly, 11-shank type
- Scarifier, shanks and points (9) for ripper
- Warning light, amber colored rotating beacon, cab roof mounted
- Alternator, 90 A, 24 V

Standard equipment may vary for each country, and this specification sheet may contain attachments and optional equipment that are not available in your area. Up to 20% blended paraffine fuel can be used. Please consult your Komatsu distributor for detailed information.

